

FIRE & SMOKE CURTAINS

APPLICATIONS FOR FIRE AND SMOKE CURTAINS
AND THE PRODUCT RANGE AVAILABLE

WWW.COOPERSFIRE.COM



coopers

SMOKE AND FIRE CURTAINS

LEADING THE WAY IN FIRE PROTECTION

COMPANY PROFILE COOPERS FIRE

Coopers Fire operates from its UK manufacturing site based along the south coast in Waterloooville. Coopers Fire offer third-party certified product design, manufacture, installation, commissioning and on-going servicing of fire and smoke barriers.

With a long established history, Coopers Fire are represented in over 40 overseas territories through a distributor network.

Coopers Fire are the original patentees of the electromechanical fail safe system, which set the benchmark for active smoke and fire barriers worldwide, and help to continue to remain a market leader using patented and proprietary technology.

Coopers Fire offer an unparalleled range of vertical and horizontal fire and smoke curtain barrier systems that are tested extensively in many different countries to many international standards meeting a wide range of regulation.



COOPERS FIRE IS A SPECIALIST MANUFACTURER OF SMOKE AND FIRE CURTAIN BARRIER SYSTEMS

COMPANY HISTORY

Coopers Fire was originally a family business manufacturing blinds and shutters dating back to 1874.

The automatic fire screen with gravity fail-safe drive system was invented and patented by Coopers Fire in 1983 and sparked a generation of smoke and fire curtain barriers. Now an industry norm, active smoke and fire barriers are available worldwide.

Coopers Fire operate with an ISO 9001 Quality Management System, ISO 14001 Environmental Management System and ISO 45001 Health and Safety Management

The product range is quality assured and built for longevity and on-going service and maintenance.

Continuous research and development has resulted in Coopers Fire always being first in their industry to comply with new standards. It was the first to comply with BS 7346-3 and CE Mark to EN 12101-1 for smoke barriers and BS 8524 for fire curtain barriers.

Coopers Fire was bought by the Lowe & Fletcher Group in 2014, who are a fifth generation family owned industrial business which was founded in 1889.



TESTING AND STANDARDS

The Engineering Department is fully equipped with 3D and 2D facilities and can provide customised services right from concept and design stage to completion. Coopers Fire offers technical expertise, with a number of its experts extensively involved in developing ISO, CEN and BS product standards.

Unlike other suppliers, Coopers Fire pride themselves on innovation and bespoke solutions which are supported by numerous internationally accredited Independent Third Party Certification Schemes for Product, Installation and Service where applicable.

Coopers Fire commitment to life safety is best expressed through dedication to ensuring that the fire and smoke curtains manufactured meet the highest international standards.

Coopers Fire test and manufacture every fire and smoke curtain in accordance with the toughest of internationally recognised accreditations, which are then independently third party certified, instilling clients with confidence in fire protection equipment that they can trust.



COOPERS INTERNATIONAL LANDMARKS

Many prestigious international landmark buildings are protected by Coopers Fire smoke and fire curtains.

Some of the iconic buildings in which Coopers Fire products are installed include the Sydney Opera House; The Louvre in Abu Dhabi; Royal Palaces at Buckingham Windsor, and St. James; London's iconic buildings like The Shard; The British Museum and The Gherkin and large shopping malls like The Mall of the Emirates and the Dubai Mall.

Coopers Fire have curtains in International Airports such as Sydney; Brisbane; Dulles, Heathrow; Gatwick; Stansted; Ataturk; Johannesburg; Düsseldorf; Chek Lap Kok; and Dubai.

Coopers Fire have also installed fire and smoke curtains in commercial buildings, offices and retail stores for brands such as Apple; Adidas; Google; McDonald's; Selfridges; Fortnum and Mason and Facebook.



APPLICATIONS FIRE AND SMOKE CURTAINS

Coopers Fire have developed a wide range of fire and smoke curtains to protect every type of building application. From protecting means of escape and boundary protection to providing a building with a system that offers effective fire and smoke compartmentation.

Commitment to life safety has led Coopers Fire to develop a wide range of fire and smoke curtain barrier assemblies fully tested to BS EN and UL standards and approved to protect various applications across a wide spectrum of building types such as retail, hospitals, commercial, airports and domestic.



ATRIUM, LOBBIES & RECEPTIONS



Prevent the spread of smoke and fire from one to floor to another in an atrium with Coopers Fire Horizontal or Concertina curtains or protect lobbies and receptions using Vertical fire and smoke curtains.

OPENINGS IN WALLS



Coopers Fire fire curtains can be used to replace non-load bearing walls and fire rated glazing offering open plan designs that still meet fire regulations.

EGRESS & CORRIDOR SEPARATION



Protect escape routes for mass evacuation. The evacU8 smoke curtain allows egress through a compartment that contains smoke. It offers the capability to split deployment to encourage safe evacuation psychology where assemblies cross potential escape routes.

BOUNDARY PROTECTION



Coopers Fire fire curtains are an approved alternative to fire shutters, fire rated glazing and firewalls whilst protecting windows from channeling fire and preventing the spread of fire from one building to the next.

APPLICATIONS FIRE AND SMOKE CURTAINS

Fire and Smoke curtains offer various solutions to architects, engineers, consultants and specifiers providing the ability to design complex buildings that adhere to fire regulations and offer protection against fire or smoke. When specifying a fire or smoke curtain system, it is essential to consider the whole package from quality, performance, installation and maintenance to after sales care. Coopers Fire offers third party certificated products as well as third party accredited installation and specialist after care packages, tailored to your specific requirements and application.



COMPARTMENTATION



Coopers Fire full range of fire and smoke curtains can be used to create compartments to contain fire and smoke and prevent it from spreading. The product range is used particularly in this instance in large open spaces in buildings.

LIFTS AND LIFT LOBBIES



Coopers Fire knowledge of the regulations protecting lifts and lift lobbies has led to the development of a range of Vertical fire curtains with smoke control approved to protect the spread of fire and smoke through lift shafts.

STAIRS AND ESCALATORS



Open up stairwells or protect escalators by using Vertical or Concertina fire and smoke curtains. The Concertina product has been used to fully encapsulate stairs or escalators to allow open plan designs, replacing fire doors and lobbies.

PROTECTED MEANS OF ESCAPE



Coopers Fire commitment to advancing fire fabric technology has led us to develop a range of insulating zone fire curtains that provide architects and fire engineers with a non-invasive, protected means of escape, in accordance with fire regulations.

PRODUCT MATRIX FIRE AND SMOKE CURTAINS

These tables will help assist you with the type of fire or smoke curtain product required.

These tables represent maximum product certification dimensions for each product model. For maximum possible working dimensions please contact Coopers Fire.

BS 8524-1 FIRE CURTAINS (Products suitable for the UK and other countries)

PRODUCT NAME	ORIENTATION	MAX WIDTH AND MAX DROP	FIRE RESISTANCE OR CLASSIFICATION	SMOKE CONTROL
FIREMASTER A1 FIRE CURTAIN	Vertical - Single Roller	7m x 8m 7m x 7m	E120 EW30 E180 EW30	Yes*
FIREMASTER A1 FIRE CURTAIN	Vertical - Overlapping Roller	Unlimited x 6m	E120 EW30	No
FIREMASTER PLUS² FIRE CURTAIN	Vertical - Single Roller/ Wide Single Roller	Up to 20m max. width x up to 7m max. drop	Up to E180 EW90	Yes*
FIREMASTER CONCERTINA FIRE CURTAIN	Concertina - Open	Unlimited x 10m Unlimited x 2.85m	E120 EW30 E180 EW30	No
FIREMASTER CONCERTINA FIRE CURTAIN	Concertina - Closed	Unlimited x 2.85m Unlimited x 3.3m Unlimited x 10m	E240 EW30 E180 EW30 E120 EW30	Yes*
VIIFIRE IZONE FIRE CURTAIN	Vertical - Single Roller	2.6m x 2.8m	E180 EW60	Yes*

* Approved to BS EN 1634-3, Fire resistance and smoke control tests for door and shutter assemblies, openable windows and elements of building hardware. Smoke control test for door and shutter assemblies.

UL TESTED FIRE AND DRAFT CURTAINS (Products suitable for the US, Middle East and other countries)

PRODUCT NAME	ORIENTATION	MAX WIDTH AND MAX DROP	FIRE RESISTANCE OR CLASSIFICATION	SMOKE CONTROL
FIREMASTER A1 FIRE CURTAIN	Vertical - Single/ Overlapping Rollers	2.43m x 3.04m	240 minutes in masonry / 180 minutes in gypsum	Yes
RESQ-WINDOW VISION PANEL	Vertical - Single Roller	2.43m x 3.04m	120 minutes	Yes
FIREMASTER 4/1000 FIRE CURTAIN	Vertical - Single/ Overlapping Rollers	Unlimited x 8m	180 minutes	Yes
FIREMASTER EGRESS FIRE CURTAIN	Vertical - Single Roller	Contact Coopers Fire	180 minutes	Yes
FIREMASTER CONCERTINA FIRE CURTAIN	Concertina - Open	Unlimited Width x High	180 minutes	No
FIREMASTER CONCERTINA FIRE CURTAIN	Concertina - Closed	Unlimited Width x High	180 minutes	No
FIREMASTER CONCERTINA EGRESS FIRE CURTAIN	Concertina - Open/ Closed	3.29 x 3.32m	240 minutes	No
SMOKESTOP DRAFT CURTAIN	Vertical - Single/ Overlapping Rollers	Contact Coopers Fire	N/A	No
SMOKESTOP EGRESS SMOKE CURTAIN	Vertical - Single/Wide Single Roller	Contact Coopers Fire	N/A	Yes

BS EN 1634-1 FIRE CURTAINS (Products suitable for the UK, Europe and other countries)

PRODUCT NAME	ORIENTATION	MAX WIDTH AND MAX DROP	FIRE RESISTANCE OR CLASSIFICATION	SMOKE CONTROL
FIREMASTER A1 FIRE CURTAIN	Vertical - Single Roller	6m x 8m 6m x 7m	E120 EW30 E180 EW30	Yes*
FIREMASTER A1 FIRE CURTAIN	Vertical - Overlapping Roller	Unlimited x 6m	E120 EW30	No
RESQ-WINDOW VISION PANEL	Vertical - Single Roller	6m x 8m	E120 EW30	Yes*
FIREMASTER PLUS² FIRE CURTAIN	Vertical - Single Roller/ Wide Single Roller	7m x 7m 7.8m x 6.2m 7m x 4m	E120 EW90 E120 EW90 E180 EW90	Yes*
FIREMASTER INSUL8 FIRE CURTAIN	Vertical - Single Roller	7m x 2.46m	E240 EW240 EI,90	No
FIREMASTER CLEANROOM FIRE CURTAIN	Vertical - Single Roller	3m x 4m 4m x 4m	E120 EW120 E90 EW90	No
FIREMASTER MARINE FIRE CURTAIN	Vertical - Single Roller	2.4m x 2.692m	A-0 60 minutes	No
FIREMASTER HORIZONTAL SIMPLEX FIRE CURTAIN	Horizontal - Simplex	7m x 7m	E120 EW20	No
FIREMASTER HORIZONTAL DUPLEX FIRE CURTAIN	Horizontal - Duplex	7m x 14m 3m x 20m	E120 EW15 E60 EW15	No
FIREMASTER 4/1000 FIRE CURTAIN	Vertical - Single Roller	7m x 2.5m 7m x 8m	E240 EW30 E180 EW30	Yes*
FIREMASTER SUPERPLUS FIRE CURTAIN	Vertical - Single/ Overlapping Roller	Contact Coopers	Contact Coopers	No
FIREMASTER CONCERTINA FIRE CURTAIN	Concertina - Open	Unlimited x 10m 5m x 5m	E90 E60 EW60	No
FIREMASTER CONCERTINA FIRE CURTAIN	Concertina - Closed	Unlimited x 10m 5m x 5m	E90 E60 EW60	Yes*
VIIFIRE A1 FIRE CURTAIN	Vertical - Single Roller	5m x 3m	E120 EW30	Yes*
VIIFIRE IZONE FIRE CURTAIN	Vertical - Single Roller	5m x 3m	E180 EW30	Yes*

* Approved to BS EN 1634-3, Fire resistance and smoke control tests for door and shutter assemblies, openable windows and elements of building hardware. Smoke control test for door and shutter assemblies.

BS EN 12101 SMOKE CURTAINS (Products suitable for the UK and other countries)

PRODUCT NAME	ORIENTATION	MAX WIDTH AND MAX DROP	FIRE RESISTANCE
SMOKESTOP D600A SMOKE CURTAIN	Vertical - Single Roller	6m x 4m	150 minutes
SMOKESTOP D600A SMOKE CURTAIN	Vertical - Overlapping Rollers	Unlimited x 10.5m	150 minutes
SMOKESTOP D600A SMOKE CURTAIN	Vertical - Side by Side Overlapping	Unlimited x 6.7m	150 minutes
SMOKESTOP DH60 SMOKE CURTAIN	Vertical - Single Roller	6m x 4m	60 minutes (DH60)
SMOKESTOP DH60 SMOKE CURTAIN	Vertical - Overlapping Rollers	Unlimited x 10.5m	60 minutes (DH60)
SMOKESTOP DH120 SMOKE CURTAIN	Vertical - Overlapping Rollers	Unlimited x 4.8m	150 minutes (DH120)
SMOKESTOP CONCERTINA SMOKE CURTAIN	Concertina - Open	Unlimited x 6m	60 minutes (DH60)
SMOKESTOP CONCERTINA SMOKE CURTAIN	Concertina - Closed	Unlimited x 6m	60 minutes (DH60)
SMOKESTOP EVACU8 SMOKE CURTAIN	Vertical - Evacu8	Unlimited x 6.7m	150 minutes

VERTICAL FIRE AND SMOKE CURTAINS

Coopers Fire manufacture a range of active Vertical fire and smoke curtains that can be installed for various applications.

Vertical fire curtains are used to prevent the spread of fire within a building and can be discreetly installed to be hidden from view until required. All Coopers Fire vertical active fire curtains use the Total Gravity Fail-Safe (TGFS) system which ensures the fire curtains will activate even if there is a total power failure or short circuit. The **ResQ-Window™** vision panel can be installed into a fire curtain and allows first responders to assess areas prior to entry.

Vertical smoke curtains are used to prevent the spread of smoke and/or work as part of a smoke control system to channel smoke for extraction from a building. Smoke curtains can also be discreetly installed and activate using the Total Gravity Fail-Safe system.

Coopers Fire active Vertical fire and smoke curtains can use various fire-resistant fabrics, depending on the application, fixed to a roller and housed in a steel headbox. The curtains remain invisibly retracted until activated by an alarm or detector signal, at which time they descend safely to their operational position.

Fire and smoke curtains are available in various widths and drops (see the product matrix on pages 6 and 7) and have been tested to BS EN and UL standards.

Coopers Fire manufacture a unique intumescent fabric that can offer protection from radiant heat and be used where protected means of escape is required.



FireMaster A1 fire curtain with ResQ-Window™ installed



PRODUCT FEATURES

- **Vertical Fire Curtains** are compliant to **BS 8524-1: 2013** and **BS EN 1634-1:2014** and assessed in accordance with **BS 476-22.8:1987**. Tested to **UL Standards 10B, 10C, 10D, 1784** and **NFPA 252**
- Smoke Curtains **CE marked** and classified to **DH60** or **D600A** and assessed in accordance with **BS EN 12101-01:2005+A1:2006**. Certified for smoke and draft rating in accordance to **UL 1784** Standard
- **Unlimited widths** and **bespoke engineered** products available
- **Third Party Approved** by IFC Certification, Warrington Certification and other certification bodies
- **Integrity, Radiance and Insulated** vertical fire curtains available

VERTICAL FIRE AND SMOKE CURTAINS

Vertical fire and smoke curtains are designed to prevent the spread of fire and smoke in accordance with BS 8524-1:2013 and UL 10D for fire curtains and BS EN 12101 for smoke curtains.

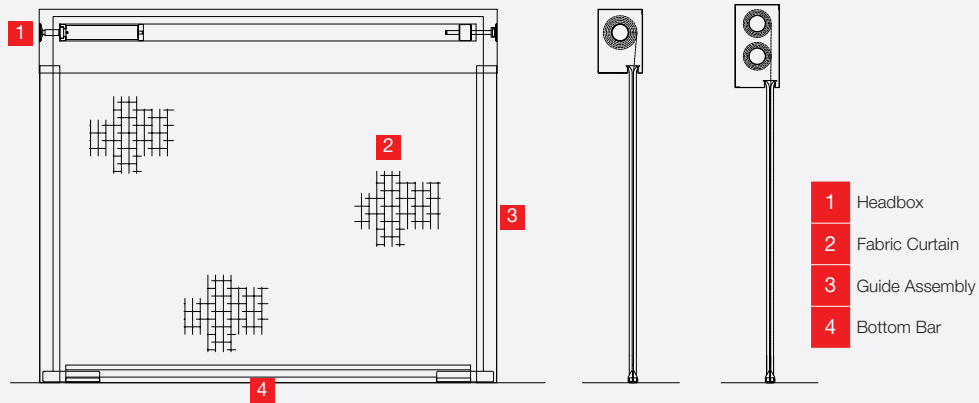

A TYPICAL VERTICAL FIRE CURTAIN



Single Roller Assembly
- used for narrower width curtains where one roller is required



Overlapping / Multiple Roller Assembly
- used for wider curtains (unlimited) where multiple rollers are required

A TYPICAL VERTICAL SMOKE CURTAIN



HORIZONTAL FIRE CURTAINS

Coopers Fire active FireMaster Horizontal fire curtains offer an alternative way to close off stairwells and atria. Horizontal curtains can be used instead of installing fire rated glazing or non-load bearing ceilings therefore creating open plan areas.

All Coopers Fire Horizontal fire curtains have No Visible Supports (NVS™) which means the unique design allows the curtain to run under tension in a guide down each side, leaving the opening free from any supports for the curtain once installed.

There are two types of the FireMaster Horizontal fire curtain, the Simplex and Duplex. The Simplex closes from one end to the other, whereas the Duplex is used for much larger areas and closes from each end of a void to meet and close in the middle.

Active Horizontal fire curtains comprise of technologically advanced fire resistant fabric encased in a compact steel housing. The fire curtain will remain invisibly retracted until activated by an alarm or detector signal, at which time they close safely to their fire operational position. Horizontal fire curtains will stop and control the spread of fire between floors in a building.

To be compliant, Fire Barriers must have a dual power supply fitted as standard. The curtain closes with mains or emergency power using a low voltage drive system.



PRODUCT FEATURES

- Fire Curtains compliant to and assessed in accordance with **BS EN 1634-1:2014**
- Alternative to fire rated glazing and non-load bearing ceilings
- **Third Party Approved** by Warrington Certification and other certification bodies
- **No Visible Supports (NVS)**

The FireMaster Horizontal is designed to prevent the spread of fire in the horizontal plane and available in a range of sizes.

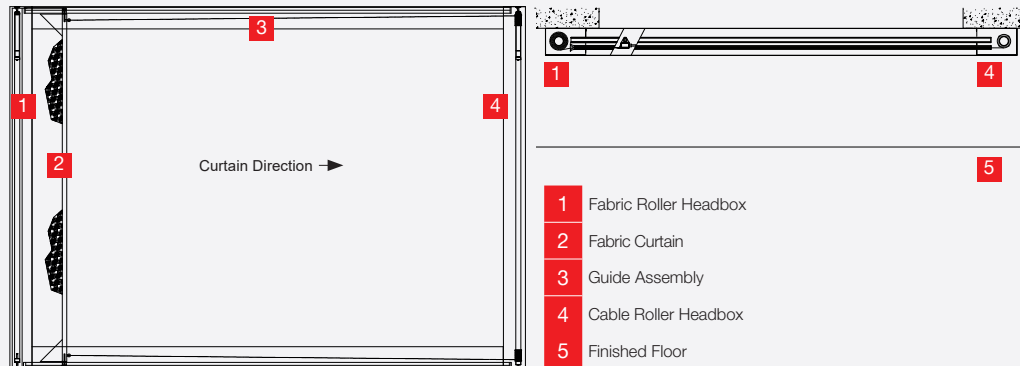

SIMPLEX™ (SINGLE BARRIER ASSEMBLY)



Suitable for smaller openings and skylights etc.

DUPLEX™ (DOUBLE CURTAIN ASSEMBLY)

Suitable for large openings including expansive atria. Complete closure in half the time.

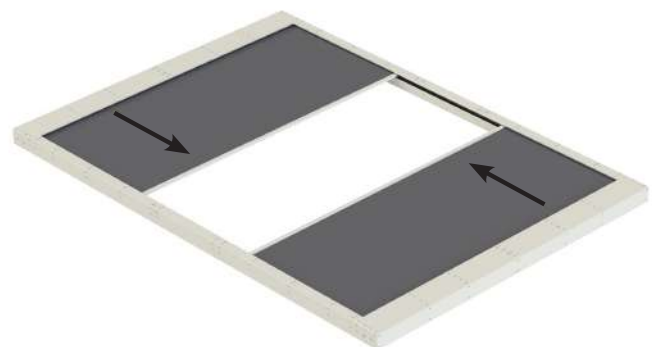

CONCERTINA™ FIRE AND SMOKE CURTAINS

The innovative active Concertina fire and smoke curtain offers greater flexibility to designers to create open plan buildings that remove the requirement for columns or corner posts and intrusive ceiling interfaces that may be required for alternative fire and smoke safety products.

The Concertina can be configured in a variety of bespoke sizes and shapes, like a square or circle and an arc or trapezoid. In fact, the Concertina can be configured in most shapes in unlimited spans.

Concertina fire and smoke curtains are installed to prevent the spread of fire and smoke and are often used to close off stairs and escalators providing architects, consultants and specifiers a whole new approach to building design.

Coopers Fire active Concertina fire and smoke curtain can use various fire-resistant fabrics, depending on the application. The fabric is uniquely folded and housed in a steel headbox. The curtain remains invisibly retracted until activated by an alarm or detector signal, at which time they descend safely to their operational position.

The Concertina product benefits from the Total Gravity Fail-Safe system which ensures the curtain will deploy safely even in the event of a total power failure or short circuit.



PRODUCT FEATURES

- Concertina fire curtain compliant to **BS 8524-1: 2013** and assessed in accordance with **BS EN 1634-1:2014** and **BS EN 13501 2:2007+A1:2009**. Tested to **UL Standards 10B, 10C, 10D, 1784 and NFPA 252**
- Concertina smoke curtain is **CE marked** and classified to **DH60** or **D600A** and assessed in accordance with **BS EN 12101-01:2005+A1:2006**
- **Unlimited widths** and **bespoke engineered** products available
- **Third Party Approved** by IFC Certification, Warrington Certification and other certification bodies
- **Bespoke shapes** achievable to allow **open plan designs meet fire regulations**
- An **egress door** can be installed on both the FireMaster Concertina Open and Closed products

The unique features of the FireMaster and SmokeStop Concertina allow it to be used in place of traditional fire and smoke control elements, allowing architects, fire engineers and specifiers to create open plan designs which meet all the requirements of a building's fire and smoke control strategy.

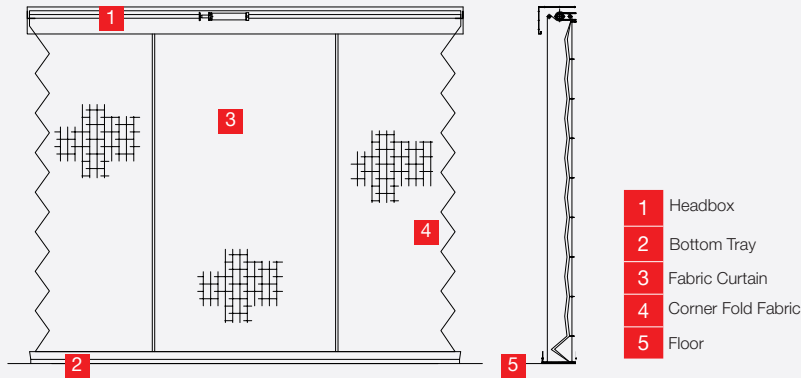

BESPOKE PRODUCT CONFIGURATIONS

Developed to provide a bespoke alternative to fixed non-loadbearing walls, partitions and fire shutters, the Concertina can be used as part of a fire engineering solution in commercial and industrial applications such as airports, shopping centres, offices and hotels or where the need for maintaining open areas for access is vital.

DIFFERENT TYPES

1. Square (Closed)
2. Faceted Curve (Open)
3. L Shaped Corner (Open)
4. Trapezoid (Closed)
5. Multifaceted (Circular Closed with egress door)



Note: Egress door available on all of the above.

Coopers Fire Vii®Fire compact vertical fire curtain provides the means to help create modern, open plan living environments in domestic homes, which are compliant with stringent fire regulations without compromising design. Sympathetic to interior aesthetics, the Vii®Fire fire curtain barrier will remain hidden until deployed. It is used to replace non-load-bearing walls, fire doors and uninsulated glazing.

The Vii®Fire product range is limited to a maximum width of 3 metres and a maximum drop of 3 metres. This range of products was introduced for use in domestic homes and areas of buildings where a compact headbox is required.

The full Vii®Fire range is easy for a competent person to install and is the first and only 'plug and play' fire curtain system. This product is also aimed at kitchen serveries and portable cabins. Being extremely compact, it remains completely invisible until required.

Vii®Fire active fire curtains can use various fire-resistant fabrics, depending on the application. The fabric is fixed to a roller which is housed in a steel headbox. The curtains remain invisibly retracted until activated by an alarm or detector signal, at which time they descend safely to their operational position. The Vii®Fire uses the Total Gravity Fail-Safe system ensuring the fire curtain will deploy safely even if there is total power failure or a short circuit.

The Vii®Fire iZone utilises a unique intumescent fabric manufactured by Coopers Fire that can offer protection from radiant heat and can be used where protected means of escape is required.

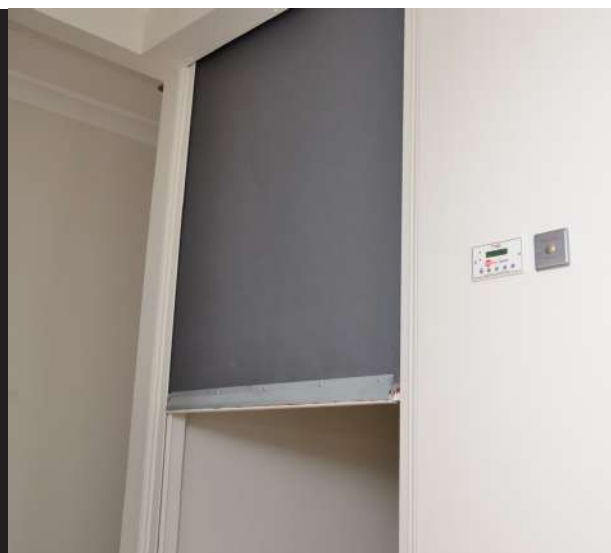

PRODUCT FEATURES

- Fire Curtains compliant to **BS 8524-1: 2013** and assessed in accordance with **BS 476-22.8:1987** and **BS EN 1634-1:2014**
- **Maximum width of 3m and maximum drop of 3m**
- **Third Party Approved** by IFC Certification, Warrington Certification and other certification bodies
- **Integrity and Radiance** vertical fire curtains available

The Vii Fire FM product is designed as a barrier to prevent the spread of fire in accordance with BS EN 1634-1:2014 and BS 8524-1:2013 and is the ideal solution for small holes in fire walls.

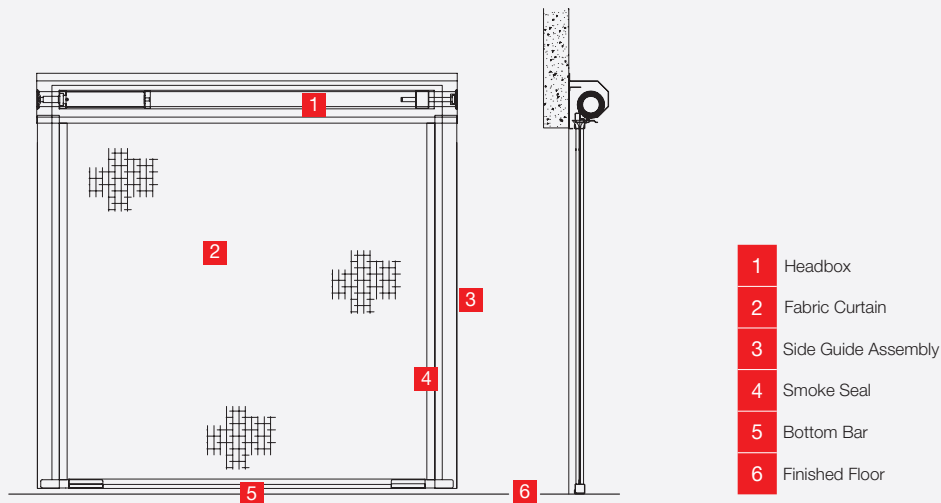

ACTIVE FIRE BARRIERS FOR THE DOMESTIC HOME

If protecting a means of escape, an insulating zone is required to protect passing occupants from radiating heat. Coopers Fire Vii®Fire i-Zone is approved to BS 8524-1:2013 and will achieve radiated heat as low as 10kW/m² after 60 minutes.

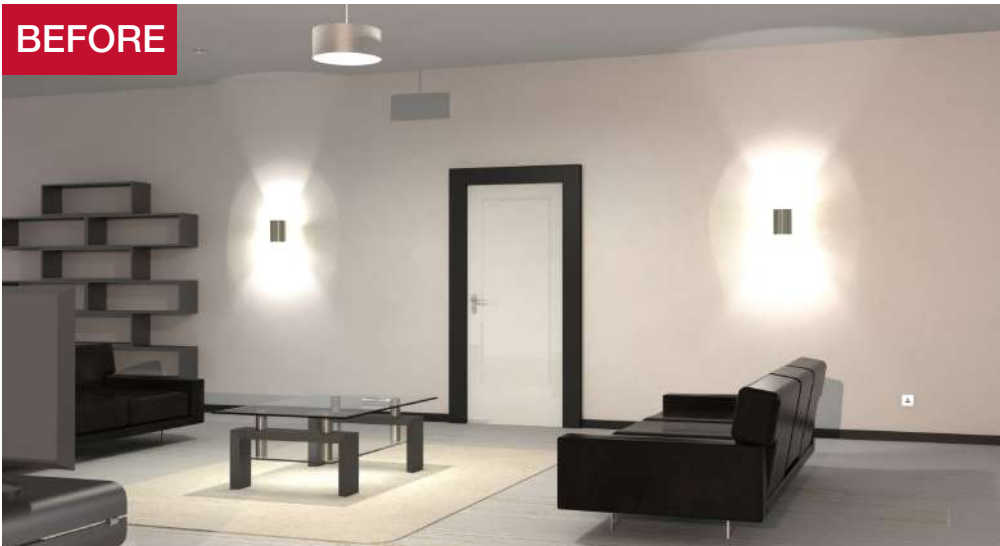

CONTROL OPTIONS VARIOSPEED®6 CONTROLS

The Variospeed®6 system is used for Smoke and Fire Curtains. It uses 24Vdc permanent magnet electrical motors with an internal 24Vdc electromagnetic brake, as standard. When the Smoke or Fire curtain(s) are fully retracted, the internal electromagnetic brake is powered, keeping the Smoke or Fire curtain(s) in their retracted position. Power to the motor is completely isolated, prolonging the life of the motor and maintaining the manufacturers supply warranty.

The motors include built in short circuit and open circuit protection, meaning the curtains will deploy under Total Controlled Gravity Fail-Safe at a descent rate compliant with standards BS EN 12101 and BS 8524 even if the motor wires are severed, i.e. shorted together or disconnected from the Motor Control Card (MCC). In the event of an alarm activation the electromagnetic brake will de-energise and the Smoke or Fire curtain(s) will immediately deploy to their Fire Operational Position under Gravity Fail-Safe.

VARIOSPEED®6 CONTROLS AT MOTOR (CAM)

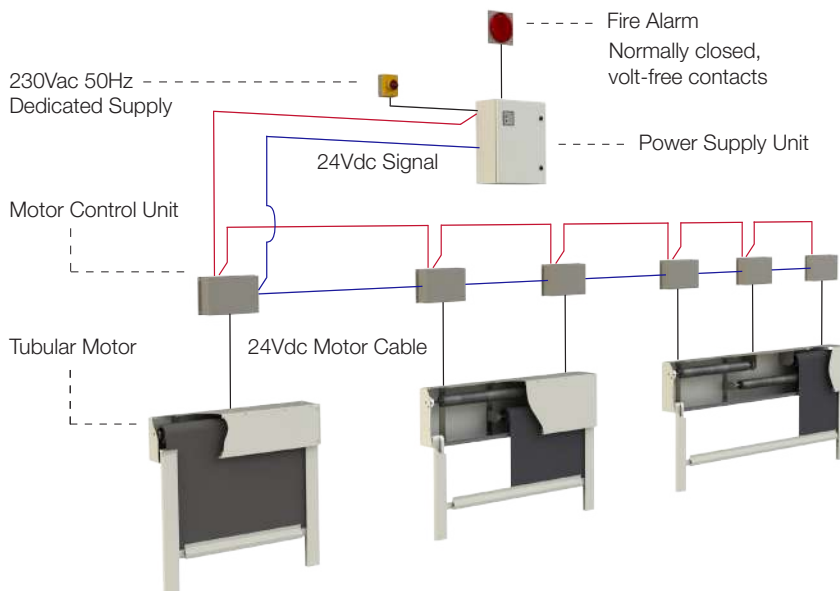

VARIOSPEED®6 CONTROLS GROUPED (CG)

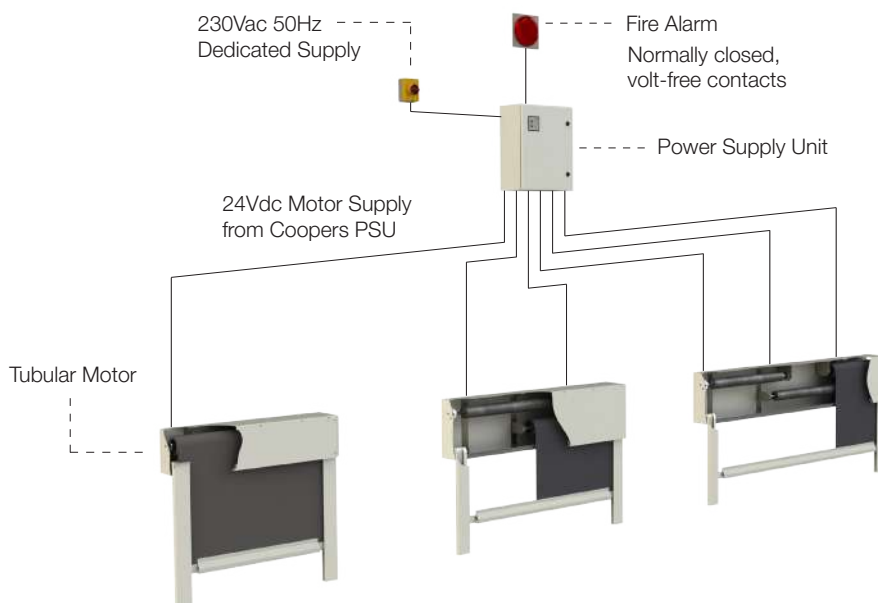

GRAVITY FAIL-SAFE

If there is a mains power failure the Smoke or Fire curtain(s) will be held in the retracted position for 30 minutes (adjustable) under Battery Backup (BBU) before deploying to their Fire Operational Position (FOP). If an alarm activation is received during a mains power failure, the curtain(s) will immediately deploy to their FOP. The Smoke or Fire curtain(s) will descend under total and controlled Gravity Fail-Safe.

PRODUCT BENEFITS

Can be connected to BMS for monitoring of system

Up to 20 fire or smoke curtain rollers from one Power Supply Unit (PSU)

Adjustable electronic descent speeds

Motor protected from short circuits or open circuits

24Vdc motors with internal electromagnetic brakes as standard

Adjustable battery backup

Multiple alarm inputs and outputs

Low power consumption

OPTIONAL EXTRAS VARIOSPEED®6 CONTROLS

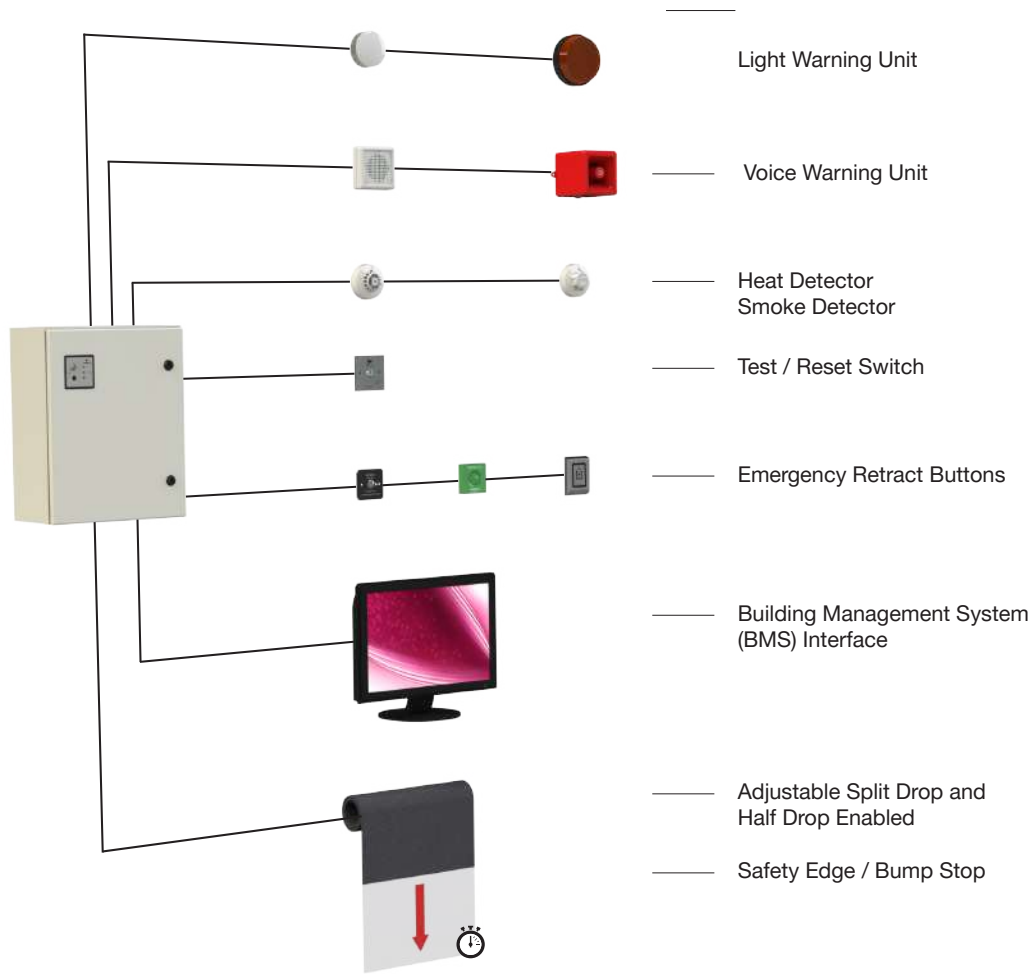

FIRE SAFETY TRAINING & SUPPORT



ENHANCE YOUR EXPERTISE WITH COOPERS FIRE CPD SEMINARS

At Coopers Fire, we offer CPD seminars to advance fire safety knowledge for the building industry. Accredited by RIBA, FIA, and CABE, our free seminars cover the latest in fire protection for Architects, Building Control Officers, Engineers, Specifiers, and Fire & Rescue Service professionals.

WHY ATTEND?

- Expert Insight: Learn about cutting-edge fire safety solutions.
- Accredited Points: Earn CPD points recognized by leading institutions.
- Stay Current: Keep up with evolving regulations and best practices.

INTERESTED?

Email cpd@coopersfire.com to learn more and book a session.

SERVICE AND MAINTENANCE

Your fire and smoke curtains are part of the building's life support system; we'll make sure that they continue to protect your building and its occupants from fire and smoke.

No matter the type of building or the make and model of the fire curtain or smoke curtain, a Coopers Fire service agreement provides peace of mind as you can be assured of the performance of your system at all times and can avoid any unexpected and costly repairs.

Coopers Fire service engineers are the only independently approved service team qualified to conduct the servicing of fire and smoke control curtains.



PLANNED SERVICE IS AVAILABLE FOR COOPERS FIRE LIFE SAFETY EQUIPMENT.

BENEFITS OF BEING A SERVICE CUSTOMER

	Service Customer	Call-Out Only
Customer Service Adviser A member of the service team will oversee your account	✓	✗
Technical Support Access to technical teams and engineers	✓	✗
Scheduled Maintenance Visits Two pre-planned visits to ensure compliance with relevant British Standards	✓	✗
Guaranteed Response Times For Emergency Calls 24hr response	✓	✗
Pre-agreed Spending Limits Avoid costly return visits and delays by utilising van stocks	✓	✗
On Site Training Provided during engineers visits	✓	✗
No Up Front Payments Setting up an account ensures no delay to repairs	✓	✗

For information, to get a quote
or to book a CPD workshop

Please call:

+44 (0)2392 454 405

or E-mail: info@coopersfire.com
WWW.COOPERSFIRE.COM

Coopers Fire Ltd
Ignis House, Houghton Avenue
Waterlooville, Hampshire
PO7 3DU. United Kingdom

Email: info@coopersfire.com
Web: www.coopersfire.com

Coopers Fire Ltd has a policy of
continuous product improvement.

As such we reserve the right to
change design and specifications
without prior notice.

Please check our website for the
latest information.

© Coopers Fire Ltd. All content and products are copyright
of Coopers Fire Ltd. Registered in England Number: 2010274.
Multiple patents granted and pending.

MAR-008-Compact Product Brochure-09-24-v23

L&F A Lowe & Fletcher Group Company



LEADING THE WAY IN FIRE PROTECTION